



Domestic Water New Service Application

Oakdale Irrigation District

1205 East F Street

Oakdale, CA 95361

billing@oakdaleirrigation.com

209-847-0341

Applicant Information	
Last Name:	First Name:
Mailing Address:	
Phone Number:	Email:
State ID Number:	

Service Connection Information	
Service Address:	Start Date:
APN:	Owner: <input type="checkbox"/> Renter: <input type="checkbox"/>

All new residential and commercial customers are required to at the time of this request for service:

- A) Submit to the District, at the customers expense, a credit report indicating a reliable credit history,
or
 B) Provide a security deposit to guarantee payment of unpaid bills in the event of discontinuance of service or District lockout. This security deposit will be held for a minimum of 12 consecutive months (1 year). When the customer has no outstanding amounts owed to the District, and has not been delinquent during the past 12 consecutive months, the deposit shall be refunded to the customer. The 12 consecutive months start over if customer's account becomes delinquent.
- For the protection of the public water distribution system from contamination or pollution due to backflow through the water service connection, an OID approved backflow prevention device must be installed prior to water service being activated. OID approved backflow prevention devices are as follows:
 - Watts Model 009
 - Wilkins Model 975XL
 - Febco Model 825Y
 -Please refer to attached "Assembly Installation Diagram #1" for more detail.

I hereby apply for water service at the above premises. I agree to use and pay for said water, in accordance with the rates and rules legally in effect, and acknowledge receipt of the Oakdale Irrigation District's Rural Water System's Domestic Water Policy.

Signature: _____ Date: _____

Current Schedule of Fees and Charges		
Security Deposit	\$100.00	Initial/reinstated
New Connection	\$25.25	Per occurrence
Immediate Availability Charge	\$14.40	Per month
Base Rate	\$5.70	Monthly for first 1,000 cubic feet
Water Usage	\$0.52	Per 100 cubic feet after first 1,000

Please submit application to billing@oakdaleirrigation.com or mail to our office at the above address.

DISCLOSURE STATEMENT

The following information is requested by the Federal Government in order to monitor compliance with Federal laws prohibiting discrimination against applicants seeking to participate in the program. **You are not required to furnish this information, but are encouraged to do so.** This information will not be used in evaluating your application or to discriminate against you in any way. However, if you choose not to furnish it, we are required to note the race/national origin of individual applicants on the basis of visual observation or surname.

Please check one box in each of the following categories:

Ethnicity Category:

- Hispanic or Latino
- Not Hispanic or Latino

Race Category:

- American Indian or Alaska Native
- Asian
- Black
- Native Hawaiian or Other Pacific Islander
- White

Name

Date

SERVICE ADDRESS

This institution is an equal opportunity provider.

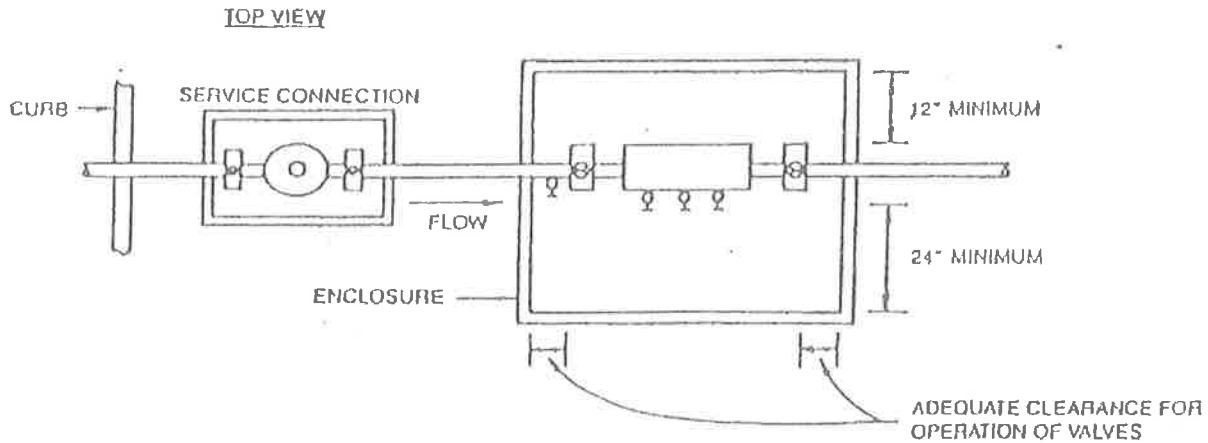
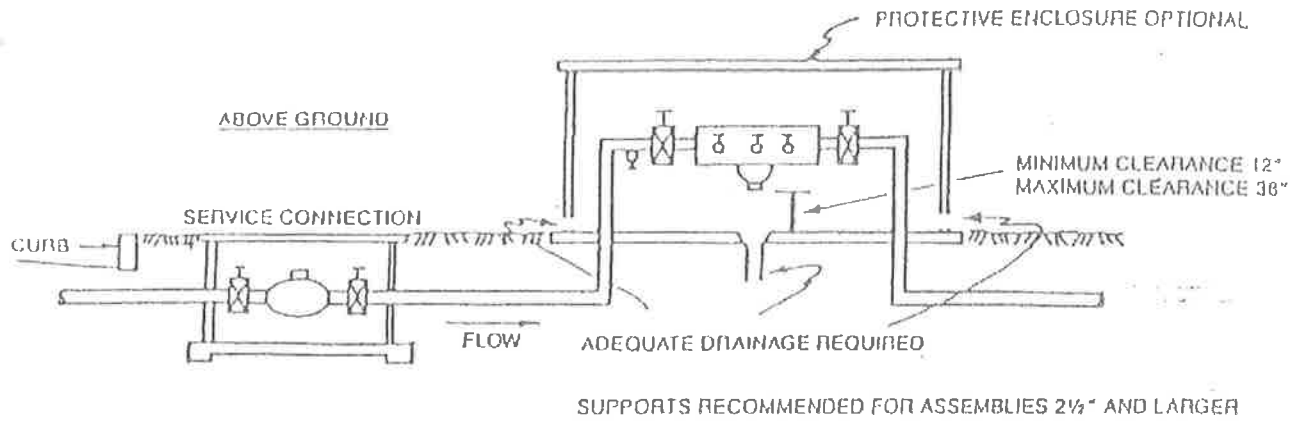

OAKDALE IRRIGATION DISTRICT
 APPROVED BACKFLOW PREVENTION
 ASSEMBLY INSTALLATION DIAGRAM #1

No outlet, tap, tee or connection on the water line between the water meter and the assembly.

Note that installation of a backflow prevention assembly will prevent release of on-site pressure to the utility water mains. Therefore, it is important that a temperature/pressure relief valve be properly installed to relieve any excessive increase in on-site pressure due to hot water heating systems or other activities. Also Thermal Expansion Protection is recommended.

The assembly should be sized equal to the water service pipe diameter or larger in accordance with the flow requirements.

The assembly shall be inline repairable and testable with no obstruction in front of the 4 test cock valves.

The assembly should be protected against freezing as needed.

The assembly is only approved for horizontal orientation.